



PTE240 Protector

Introduction

Since 1980, Eaton Innovative Technology has provided Surge Protective Devices (SPDs) to power quality equipment users around the world. Whatever your electrical surge protection need may be, Eaton Innovative Technology has a Surge Protective Device to fill it!

General Features

- Peak Surge Current — 300 kA per phase; 150 kA per mode
- ANSI/IEEE C62.41 Location Categories — B and C
- Application — High Exposure Level, industrial applications including: large service entrances, large distribution panels, and large individual equipment disconnects.
- Warranty — 20-Year Free Replacement
- Agency Listings — Compliant to UL® 1449 3rd Edition* and UL 1283*
- Manufacturer Qualifications — ISO® 9001:1994 Quality System Certification BSI FM 30833

Mechanical and Electrical Features

- Enclosure — Powder Coated Steel, weatherproof; NEMA® Type 4 (IP66), meets or exceeds Type 12, 13 & 3R ratings
- Connection — All connections: box terminal #14-1/0 (2.5 – 50 mm²) wire size
- Weight — ≈30 lbs (14 kg)
- Operating Temperature — -40 to 185°F (-40 to 85°C)
- Protection Modes — All Mode L-N, L-L (normal mode), L-G, N-G (common mode)
- Input Power Frequency — 47–64 Hz
- Response Time — <1 nanosecond

Note: For applications utilizing a ground fault circuit interrupting (GFCI) main breaker, please use the PTX model.

- Diagnostics — LED indicators, 1 per phase, normally on
- Remote Alarm Form C (Volt Free) relay, contact rating 60 W, or 125 Vac @ 0.5 Amp, or 30 Vdc @ 1 Amp
- Overcurrent Protection Device Requirement — Reference installation instruction for details
- Maximum 40dB EMI/RFI attenuation per Mil-Std 220 at 100kHz
- Nominal Discharge current* (I_n) = 20kA
- Active Tracking Network (ATN®)

Optional Features and Equipment

- Audible Alarm, Surge Counter and Phase Loss Monitor (S.M.A.R.T.) — (-SD suffix)
- Stainless Steel, Type 4X enclosure — (-SS suffix) (contact factory, minimum quantities apply)
- Fused — (-L suffix) (See the Eaton Web site for current field drawings)
- Fused Disconnect — (-D suffix) (See the Eaton web site for current field drawings)
- Integrated Circuit Breaker* (-C suffix)
- Integrated Circuit Breaker with External Disconnect* (-CD suffix)

* Available 1Q09

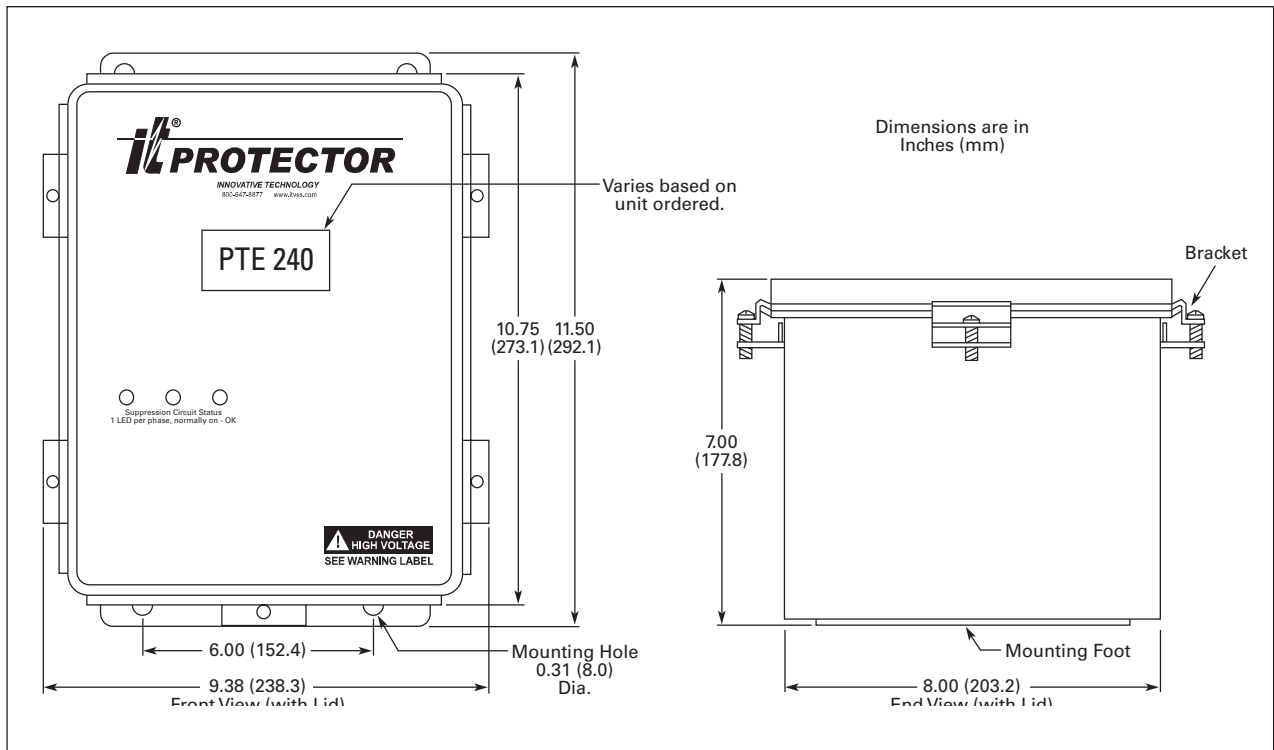

Performance Data

ANSI/IEEE C62.41-1991 Measured Limiting Voltage*

PTE120	System Config	Nominal System Voltage	MCOV	PTE Models A1 Ring Wave 2 kV, 67 A 90° Phase Angle		ALL Models B3/C1 Impulse 6 kV, 3 kA 90° Phase Angle		ALL Models C3 Impulse 20 kV, 10 kA 90° Phase Angle		UL 1449-2 Suppressed Voltage Ratings		UL 1449-3 Voltage Protection Rating **
				L-N L-G HiL-N	L-L N-G HiL-G	L-N L-G HiL-N	L-L N-G HiL-G	L-N L-G HiL-N	L-L N-G HiL-G	L-N L-G HiL-N	L-L N-G HiL-G	
1P201	Single-Phase 2w+grnd	200, 208, 220, 230, 240, 277	320	450 500	— 90	890 950	— 900	1370 1360	— 1370	700 700	— 700	Consult Factory
1S101	Split-Phase 3w+grnd	100/200, 110/220, 120/240, 127/254	150/300	220 260	350 90	490 530	830 500	900 1090	1270 1150	400 400	700 400	Consult Factory
3Y101	3-Phase Y/Star 4w+grnd	100/175, 110/190, 120/208, 127/220	150/300	220 260	350 90	490 530	830 500	900 1090	1270 1150	400 400	700 400	Consult Factory
3Y201	3-Phase Y/Star 4w+grnd	220/380, 230/400, 240/415, 277/480	320/640	450 500	820 90	890 950	1630 900	1320 1360	2270 1370	700 700	1500 700	Consult Factory
3Y300	3-Phase Y/Star 4w+grnd	305/525, 347/600	420/840	520 570	910 90	1090 1150	2040 1050	1490 1630	2480 1680	1000 1000	1800 1000	Consult Factory
3D101	3-Phase Δ (Hi-Leg) 4w+grnd	120/240	150/300	220 260 450	350 90 500	490 530 890	830 900 950	900 1090 1370	1270 1150 1320	400 400 700	1500 400 700	Consult Factory
NN201	3-Phase Δ 3w+grnd	200, 208, 220, 230, 240	320	— 650	420 —	— 880	860 —	— 1370	1270 —	— 700	700 —	Consult Factory
NN400	3-Phase Δ 3w+grnd	380, 400, 415, 440, 480	580	— 1090	730 —	— 1490	1490 —	— 2120	2070 —	— 1200	1200 —	Consult Factory
NN501	3-Phase Δ 3w+grnd	525, 600	750	— 1420	970 —	— 910	1870 —	— 2620	2470 —	— 1800	1800 —	Consult Factory

* Test environment: All tests performed with 6" lead length, positive polarity. Voltages are peak ±10%. Measurements are taken from zero reference per NEMA LS-1.

** Available 1Q09



©2004–2007 Eaton Corporation
All Rights Reserved
Printed in USA
Form No. PS01006051E
November 2008