

The  
**I.T. Protector®**  
 Surge Protective Devices

# PTE400 / PTX400



**T**he 400 kA per phase, 200kA per mode PTE400 and PTX400

models of the Protector® are designed to safeguard **high priority systems** and load equipment in heavy industrial environments and applications. These applications demand only the most effective and durable protection available. Installation of the PTE400/PTX400 assures damaging transients are intercepted before they reach critical loads. Effective in stand-alone applications or as part of **The I.T. System Shield®** integrated facility-wide protection plan\*, the PTE400/PTX400 models are the answer when downtime is not an option.

**StatScan™ System Diagnostics**

- N/O, N/C (Volt Free) Dry Relay Contacts
- LED indicators

**S.M.A.R.T.™ Advanced Diagnostics Option**

- Adds multi-function dual mode surge counter plus phase status indicator

**Multi-point mounting feet and Threaded conduit fitting**

**NEMA 4 (IP66) Weatherproof Enclosure**



**Compact Size**

- Application flexibility
- Close proximity mounting
- Short parallel lead length
- Optimal measured limiting voltage performance

**Transient Control System™ (TCS)**

- Total circuit component integration
- Symmetrical multi-mode current sharing
- Advanced Surge Path Technology™
- Optimal measured limiting voltage performance

**Active Tracking Network (ATN®) Option**

- Highest protection for critical loads
- EMI/RFI filter

**Circuit Encapsulation**

- Eliminates adverse environmental factors
- Extends component life
- Provides high dielectric isolation

**Unit Listings**



EXCLUSIVE I.T. 20 YEAR **Best in the Industry**

**20** WARRANTY



FREE REPLACEMENT

ISO 9001 US LISTED 1449 1283

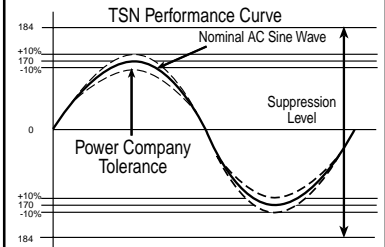
## Standard Features | Benefits

<p><b>Advanced Surge Path Technology™</b></p>	<p>All surge paths are peak surge current rated far in excess of highest known magnitude transients and are designed for ultra low impedance and conduction of high frequencies.</p>
<p><b>Enhanced All Mode Protection™</b></p>	<p>All possible transient paths to load equipment are covered. Highest level of protection.</p>
<p><b>Threshold Suppression Network™(TSN)</b></p> 	<p>Industry best suppression of high energy impulse generated transients and widest range of application compatibility. UL1283 listed EMI/RFI filter network. Standard on PTX models.</p>

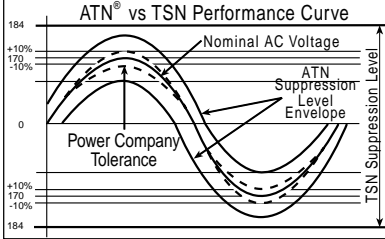
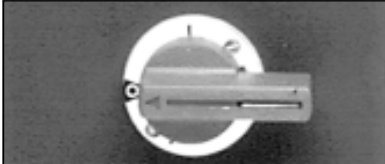
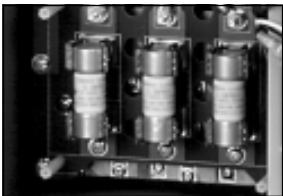
## Optional Features | Benefits

<p><b>Active Tracking Network (ATN®)</b></p> 	<p>Multi-stage hybrid ATN provides the industry's best suppression of both switching generated ringing and high energy impulse generated transients. Highest level of protection for critical and sensitive loads. The ATN circuit's measured limiting voltage performance is independently tested and verified. UL1283 listed EMI/RFI filter network. Standard on PTE models. <b>ATN option is designated by an "E" in the model name (i.e. PTE400-3Y101). PTX400-3Y101 is without ATN.</b></p>
<p><b>Integral Disconnect Switch</b></p>  	<p>Allows unit to be taken off line with minimal impact to facility operation. Includes 200KAIC surge rated and listed internal fuses allowing unit to be installed without external circuit interrupt for maximum application flexibility. <b>Fused disconnect option is designated by "D" suffix after the model number (i.e. PTE400-3Y101D or PTX400-3Y101D)</b></p>
<p><b>Suppression Monitoring and Recording Technology™ S.M.A.R.T.™</b></p> 	<p>Comprehensive monitoring of critical system functions. Real time audible and visual reporting of unit status, phase loss/protection loss and transient events (reset and alarm mute). Dual function surge counter provides non-volatile event history recording. Option carries a 10 yr. warranty separate from TVSS warranty. <b>S.M.A.R.T. diagnostics option is designated by a "-SD" suffix after the model number (i.e. PTE400-3Y101-SD or PTX400-3Y101-SD)</b></p>

## GENERAL SPECIFICATIONS

**Description:** Parallel configured, 400kA per phase, 200kA per mode **Multi-Circuit Transient Voltage Surge Suppressor (MCTVSS®)**, with remote alarm capability. Optional integral fused disconnect switch. Optional S.M.A.R.T. advanced diagnostics.

**Application:** Location Categories C, B & A - High Exposure Level, heavy industrial applications including: large service entrances, large distribution panels and large individual equipment disconnects.

**Warranty:** Twenty Year Free Replacement

**Unit Listings:** UL1449 SECOND EDITION, cUL, UL1283 filter. Peak surge current capability conforms to NEMA LS-1 conventions.

**Manufacturer Qualifications:** ISO 9001:1994 Quality System Certification BSI FM 30833

## MECHANICAL SPECIFICATIONS

**Enclosure:** Steel, NEMA 4 (IP66) - weatherproof enclosure (meets and exceeds NEMA 12, 13 and 3R ratings).

**Mounting:** Internally threaded conduit fitting (included) and multi-point mounting feet.

**Connection: Standard-** box terminals, #6 - 1/0 (13.3mm<sup>2</sup> - 53.5mm<sup>2</sup>) wire. **Fused Disconnect-** Phases: box terminals, #10 - 3 (5.3mm<sup>2</sup> - 26.7mm<sup>2</sup>) wire. Neutral & Ground: Terminal Block, #10 - 6 (5.3mm<sup>2</sup> - 13.3mm<sup>2</sup>) wire.

**Shipping Weight:** ≈ 27 kg (60 lbs.)

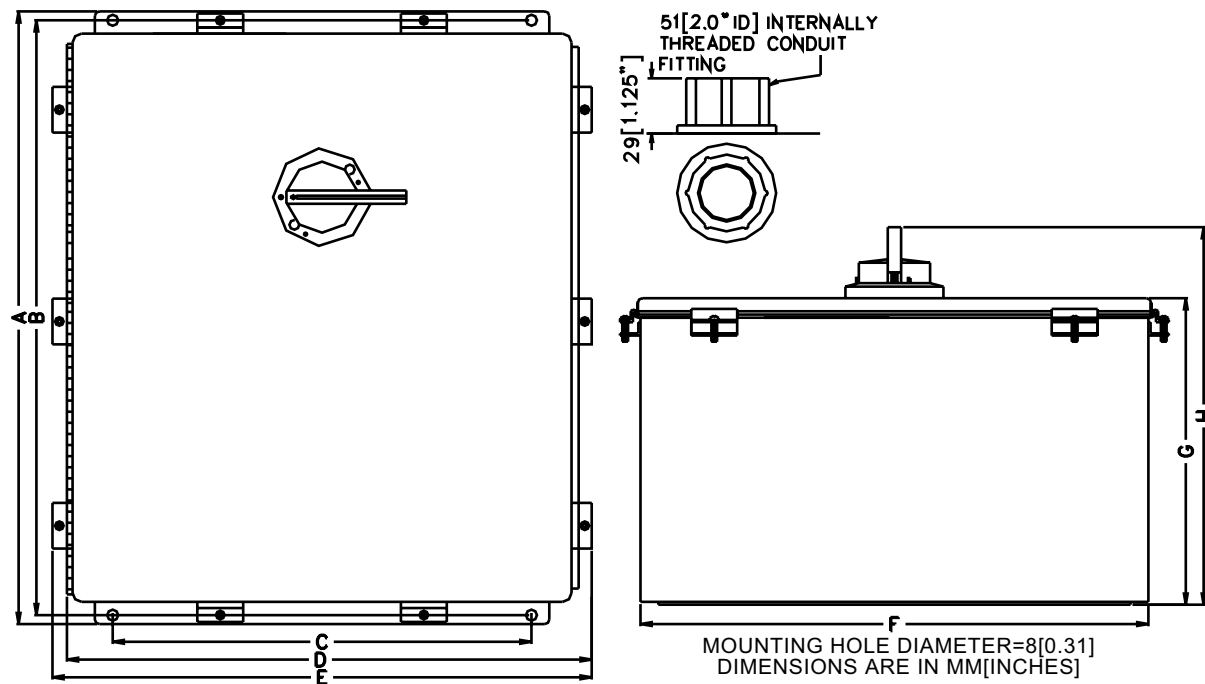

Model Option	Dim A	Dim B	Dim C	Dim D	Dim E	Dim F	Dim G	Dim H
<b>Standard</b>	445[17.50]	425[16.75]	305[12.00]	n/a	391[15.38]	356[14.00]	210[8.25]	n/a
<b>Fused &amp; Disconnect</b>	445[17.50]	425[16.75]	305[12.00]	379[14.94]	n/a	356[14.00]	210[8.25]	260[10.25]

## ELECTRICAL/PERFORMANCE SPECIFICATIONS

**Circuit Design:** Parallel configured, Threshold Suppression Network™ (TSN) utilizing Transient Control System™ (TCS) design, circuit encapsulation and Advanced Surge Path Technology™.

PTE adds multi-stage hybrid Active Tracking Network (ATN®).

**Protection Modes:** All Mode: L-N, L-L (normal mode), L-G, N-G (common mode)

**Input Power Frequency:** 50-420Hz (50-60Hz with ATN option)

**Response Time:** PTE active <1 nanosecond, PTX ≤1 nanosecond

**EMI/RFI Attenuation:** Up to 42dB normal mode, up to 41dB common mode

**Capacitance:** Up to 15nf per mode (up to 6.6µf per mode with ATN option)

**NOTE:** For applications where leakage current may be of concern please utilize PTX models.

**StatScan™ Circuit Diagnostics:** LED indicators, 1 per phase, normally on. Remote Alarm Form C (Volt Free), N/O or N/C contacts, internal terminal strips and weatherproof fitting. Optional **S.M.A.R.T.** (surge counter and phase loss indicator).

**Circuit Interrupt :** Standard external or optional integral fused disconnect switch

Model Selection Guide and Key Performance and Electrical Specifications					
Available Models	System Config	Nominal System Voltage (rms)	ANSI/IEEE C62.41-1991 Measured Limiting Voltage Tests* Test Category		
			PTE Models A1 Ring Wave 2,000V, 67A 180° Phase Angle	All Models B3/C1 Impulse Wave 6,000V, 3,000A 90° Phase Angle	All Models C3 Impulse Wave 20,000V, 10,000A 90° Phase Angle
PTE400-1S101 PTX400-1S101	Split φ 3w+grnd	100/200, 110/220, 120/240, 127/220	L-N 90, L-L 90 L-G 130, N-G 100	530, 910 580, 550	890, 1330 1000, 1020
PTE400-3Y101 PTX400-3Y101	3φ Y/Star 4w+grnd	100/200, 110/220, 120/208, 127/220	L-N 90, L-L 90 L-G 130, N-G 100	530, 910 580, 550	890, 1330 1000, 1020
PTE400-3Y201 PTX400-3Y201	3φ Y/Star 4w+grnd	220/380, 230/400, 240/415, 277/480	L-N 90, L-L 130 L-G 110, N-G 50	590, 920 620, 980	1280, 1510 1220, 1590
PTE400-3Y300 PTX400-3Y300	3φ Y/Star 4w+grnd	305/525, 347/600	L-N 110, L-L 171 L-G 140, N-G 55	820, 1220 840, 1300	1460, 1790 1440, 1930
PTE400-3D101 PTX400-3D101	3φ Hi LegΔ 4w+grnd	120/240	L-N 90, L-L 90 L-G 130, N-G 100 HiL-N 90, HiL-G 90	530, 910 580, 550 910, 910	890, 1330 1000, 1020 1400, 1400
PTE400-NN201 PTX400-NN201	3φ Δ 3w+grnd	200, 208, 220, 230, 240	L-L 40 L-G 490	860 870	1240 1360
PTE400-NN400 PTX400-NN400	3φ Δ 3w+grnd	380, 400, 415, 440, 480	L-L 70 L-G 890	900 1080	1650 1780
PTE400-NN501 PTX400-NN501	3φ Δ 3w+grnd	525, 600	L-L 170 L-G 1180	1130 1360	1790 1920

**Option Designators:** PTE-Active Tracking Network, PTX-Threshold Suppression Network; D suffix-integral fused disconnect switch. i.e. PTE400-3Y101D, PTX400-3Y101D. -SD suffix-S.M.A.R.T. diagnostics. i.e. PTE400-3Y101-SD, PTX400-3Y101D-SD

\*Measured Limiting (Let-Through) Voltage Test Environment: All modes tested dynamic except N-G, Positive polarity. All voltages are peak (±10%), Time base = 1ms. 180°phase angle voltages are measured from the zero crossing, 90° phase angle voltages from the positive peak, of the sine wave to the positive peak of the surge. All tests performed with 6 inch (152.4mm) lead length with lead lines tied together, simulating actual installation. Options offered may result in performance variance.

